

MVPGT-21 CASSETTE FILTERS – EXTENDED FILTER SURFACE WITH OPTIMIZED PERFORMANCE

FINE FILTERS FOR GAS TURBINES AND COMPRESSORS

FILTER TYPE	FILTER CLASS TO ISO 16890	FILTER CLASS TO EN 779:2012	FILTER CLASS TO EN 1822:2009
MVPGT 85-21	ISO ePM2,5 70%	F 7	–
MVPGT 95-21	ISO ePM1 70%	F 8	–
MVPGT 98-21	ISO ePM1 85%	F 9	–
MVPGTE10-21	ISO ePM1 95%	–	E 10
MVPGTE11-21	ISO ePM1 > 95%	–	E 11

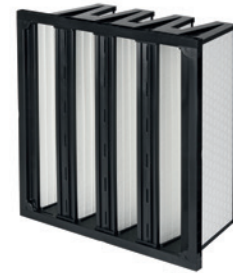

The application

Viledon® MVPGT-21 cassette filters offer operational reliability and cost efficiency for intake air filtration of

- gas turbines in power generation and in the oil and gas industry
- compressors and diesel and gas engines

The characteristics

- MVPGT-21 filters are constructed for simple handling at installation.
- Micro-glassfiber papers with hydrophobic fibers are used as filter media.
- The entire filter element is non-corroding, and fully incinerable, since it contains no metal parts. The frame consists of halogen-free plastic.
- For high performance requirements MVPGT-21 cassette filters are optimized in terms of an extended filter surface of 21 m².
- The leak-proof casting of the dimensionally stable media pleat pack and frame components provides high

burst strength, as well as excellent security against dust penetration during operation.

The special features

- MVPGT-21 cassette filters are supplied with protection grids fitted to minimize risk of damage to the filter during operation and optionally with a foamed-in place gasket.

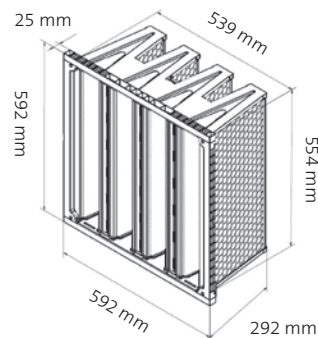

- The recessed vertical rails allow full usage of a directly attached prefilter panel resulting in longer lifetimes and lower pressure drops.
- A lug between the two inner V's allows easy handling.
- The frame offers various possibilities for the installation of clips to hold prefilters.
- Optionally installed pins can be used for combination with other pre- or final filters by using the patented Viledon® modular clip-on system.
- For demanding coastal, industrial or offshore conditions we recommend our field-proven MaxiPleat cassette filter range.

GEOMETRIES AVAILABLE		1/1	1/2
Nominal volume flow rate	m³/h	4,250	2,000
Filtering area	m²	21	8.5
Front frame for mounting frame	mm	592 × 592 × 25 610 × 610	287 × 592 × 25 305 × 610
Overall depth	mm	292	
Weight, approx.	kg	6.9	3.3
Temperature-resistance	°C	70	
Moisture-resistance (rel. hum.)	%	100	

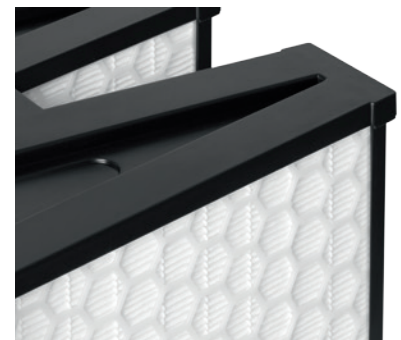

TECHNICAL FILTER TEST DATA TO EN 779 AND ISO 16890

Fractional collection efficiency curves

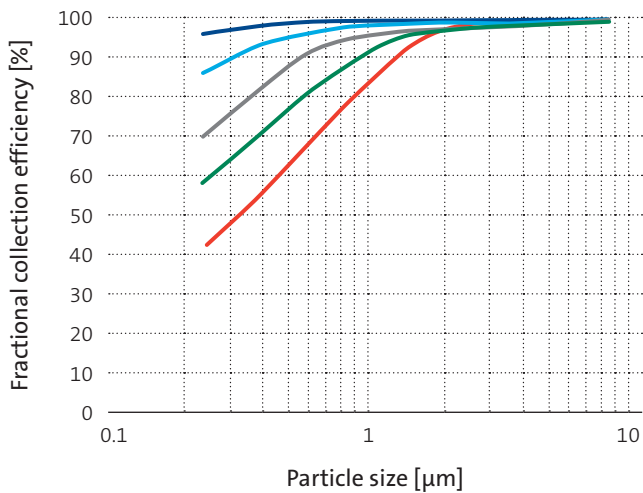

Initial pressure drop curves

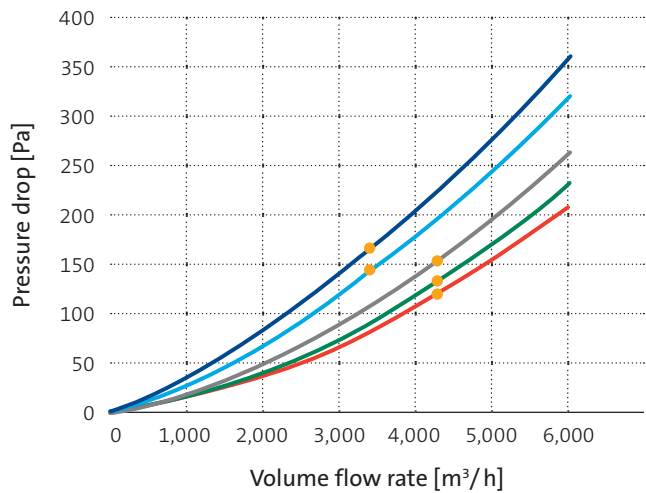

— MVPGT E11-21 — MVPGT E10-21 — MVPGT 98-21 — MVPGT 95-21 — MVPGT 85-21 ● Nominal volume flow rate

KEY DATA		MVPGT 85-21	MVPGT 95-21	MVPGT 98-21	MVPGT E10-21	MVPGT E11-21
Nominal volume flow rate ●	m ³ /h	4,250	4,250	4,250	3,400	3,400
Initial pressure drop	Pa	120	130	150	145	165
Class to ISO 16890		ISO ePM2,5 70%	ISO ePM1 70%	ISO ePM1 85%	ISO ePM1 95%	ISO ePM1 > 95%
Particulate matter efficiency						
ISO ePM1		60	70	86	95	98
ISO ePM2,5	%	70	78	91	97	99
ISO ePM10		90	93	97	99	>99
Cut-off particle size	µm	5	4	2.5	1	0.5
Filter class to EN 779:2012		F 7	F 8	F 9	E 10	E 11
EN 1822:2009						
Minimum efficiency for MPPS	%	—	—	—	≥ 85	≥ 95
Recom. final pressure drop*	Pa	600				
Maximum final pressure drop	Pa	1,000				
Dust holding capacity approx. AC Fine up to 635 Pa	g	1,300	1,200	1,100	1,000	900

* For cost-efficiency or system-specific reasons it may be appropriate to change the filters before reaching the final pressure drop stated. It can also be exceeded in certain applications.

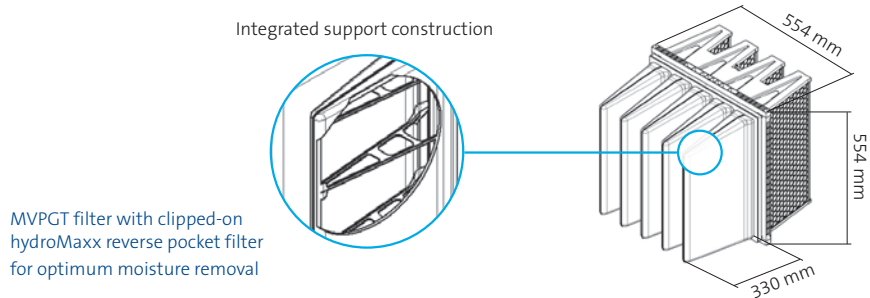

The figures given are mean values subject to tolerances due to the normal production fluctuations. Our explicit written confirmation is always required for the correctness and applicability of the information involved in any particular case. Subject to technical alterations. You will find instructions on how to handle and dispose of loaded filters in our information on product safety and eco-compatibility.